

Preparation Guidelines for Poster Sessions

Poster sessions are scheduled for a 1 hour time slot each day of the convention. The audience should be able to understand the poster's concept even if the presenter is not standing beside the display. The cork board on which each poster will be mounted is 4X8 and your display should fit inside the wood frame, so your display should be smaller than the dimensions of 4X8.

Type and Text

When you first plan out your poster display, you will need to consider how much text is going to appear in the display. It's very useful to have text read clearly from 5 feet away. Using upper and lower case is preferable to using upper case only. The shapes of words are more readily recognized in lower case. A simple block type and bolded is suggested.

For Example:

Having Fun at TESOL

This type generally reads very well. The best type size for titles on the board is between 2 and 3 inches high (around 200 -255 point). The size of additional text needs to be at least 24 point so that it can be read from several feet away.

For Example:

(24 point) Here are questions to ask about having fun at TESOL

Remember, however, that the amount of text should still be limited. (If you feel stymied by the text constraint, you can always put together an epic handout...)

As for the actual lettering of the titles and text, you can use whatever medium is available to you: computer generated type, felt pens, cut-out, stencil or rub-on letters are all effective. If you decide to hand-letter the titles and text, you can always "rough" the text in pencil first and then "ink" over the pencil guides. Please make sure that everything is legible and easy to read.

The Illustrations

The following are hints that may be helpful in creating effective illustrations:

- Use photos or other artwork that are large enough to be seen without standing right next to the poster.
- Keep all illustrations simple and bold

- Try to make all charts and tables into bold graphic color displays where the text is minimized and the symbols are maximized.

Assembly Before the Conference

The cork board on which you will be mounting your poster display does not make an attractive backing. Creating a background greatly enhances your display. This can be easily achieved with construction paper, bulletin board paper (made for this purpose), and solid color wrapping paper or fabric.

For traveling purposes, be sure that your display breaks down into elements that can be carried easily. It's a good idea to be able to carry your display onto the plane in order to avoid the lost luggage syndrome. Check with your airline for the carry-on specifications. You may want to laminate the parts that are fragile or which need to be protected.

Before you leave lay out the display on the table or floor take a picture or make a sketch so that you can re-assemble it quickly and accurately on-site.

General Suggestions

There are no absolutes in poster preparation. Your subject matter, imagination and spatial constraints will guide you better than any set of rules. However, there are a few things you may want to consider before setting up your display.

- The title should be prominently placed on your display
- Color or dark and lights will draw attention to the poster
- Type or lettering (for main ideas) that is large enough to read from several feet away
- White space and an uncluttered design to emphasize the subject matter
- Text should be in brief and clear block type
- A straightforward organization or flow

Handouts for poster sessions are highly coveted and should be prepared to address the basic concepts of the board. It should not be more than one page front and back. You should expect about 150 attendees. It is also recommended that one copy be given to Sack Sitters on the exhibit hall floor for those attendees that were not able to attend the session. The handouts should have the contact name and email address of the presenter for follow up questions about the poster.

Do not just pin up pages of a report or paper this is not considered a proper poster display.

The Design

The key to an inviting poster display is an uncluttered straightforward design. The layout suggestion below is taken from the 1993 TESOL Poster Session guide.

8'

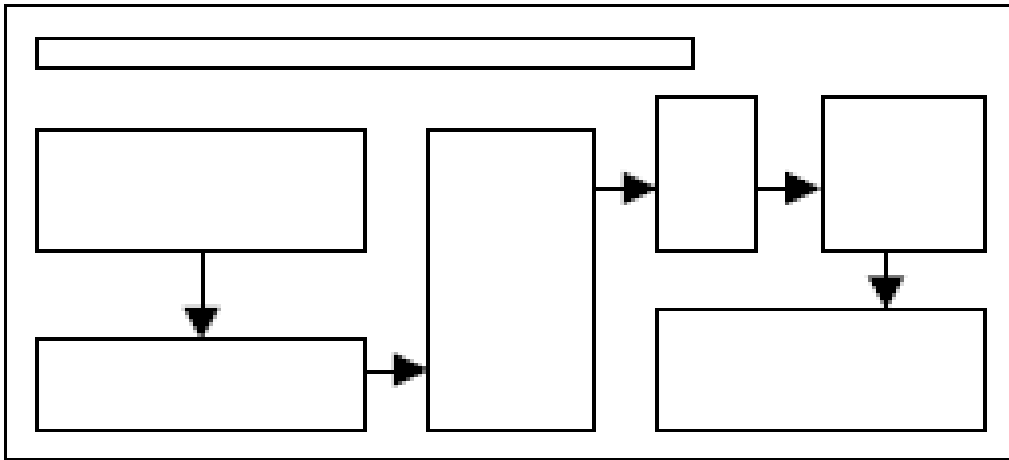

Note that the various elements are different size and orientation. There is space between each of the elements and a definite area for highlighting on aspect of the presentation. Arrows are used to direct the viewer through the display, and the flow is very natural.

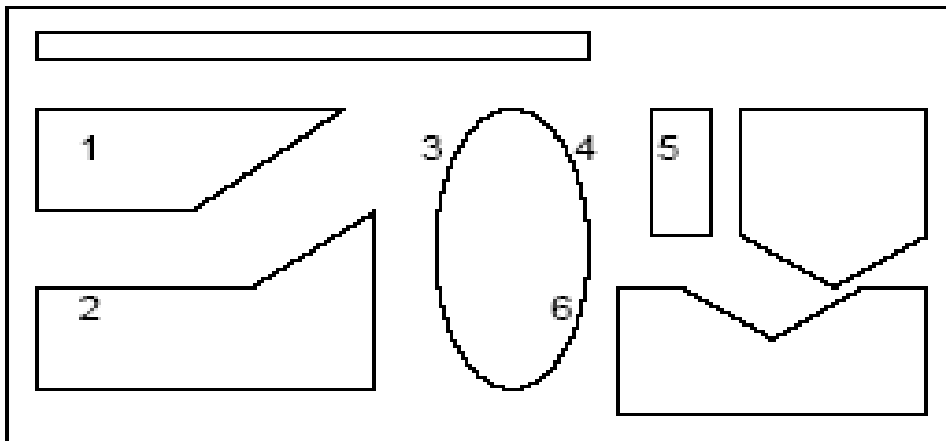

In this view the layout has some different shapes and numbers are used to draw the viewer in.

Of course, it is not necessary to have a collection of boxes on your board – a more organic, circular presentation works too. It's often helpful to ask an objective colleague to give you feedback on your display.